

Product Features

- Pressure control panel
- VSR-3 Series single-stage regulator
- Brass chrome plated body for inert, reactive, flammable and oxidizing gas and mixtures up to grade 6.0
- Stainless steel 316L body for corrosive gases
- Modular design
- Diaphragm type shut-off valves
- Suitable for inlet pressure up to 300 bar
- Easy installation into safety cabinet for gas cylinders
- Tested for use with oxygen



Typical Applications

- Component Testing
- Calibration Systems
- Laboratory Pressure Control
- High Pressure Sampling Systems
- Service & Test Equipment

Technical Data

Type:	single-stage
Inlet pressure P1:	max. 300 bar
Outlet pressure P2:	2/4/10/20/35/50 bar
Materials	
Body regulator:	see ordering info
Valve seat (regulator):	PCTFE
(shut-off valve):	PCTFE
Diaphragm (regulator):	Hastelloy®C276
(valve):	Elgiloy®
O-ring:	Viton® (FKM)
(option)	Kalrez® (FFKM)
Filter:	SS 316L
Inlet connection:	1/4"NPT(F)
Outlet connection:	1/2"NPT(F)
Temperature range:	-30°C to +74°C
Leak rate (to atmosphere):	1x10 ⁻⁸ mbar l/s He
(via seat):	1x10 ⁻⁶ mbar l/s He
Weight:	4.9kg

Schematic Drawing

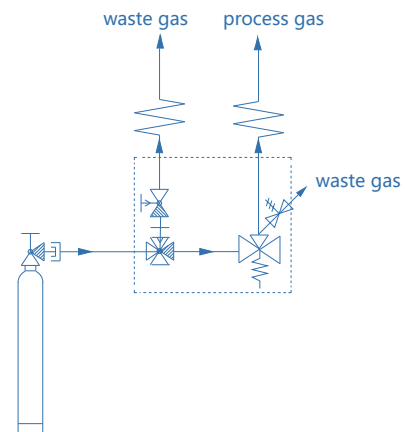

Flow Chart

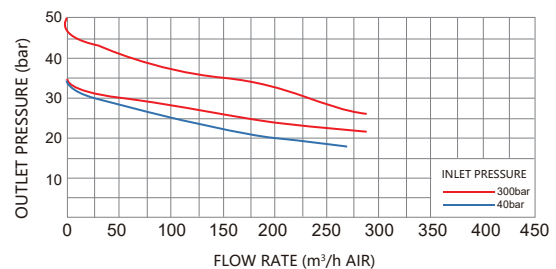
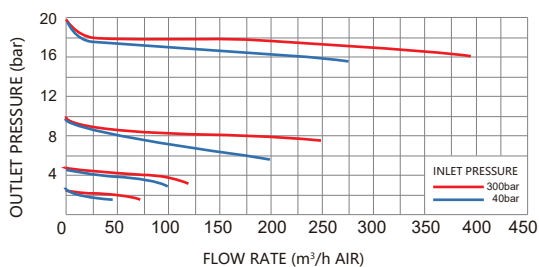

Dimensions (mm)

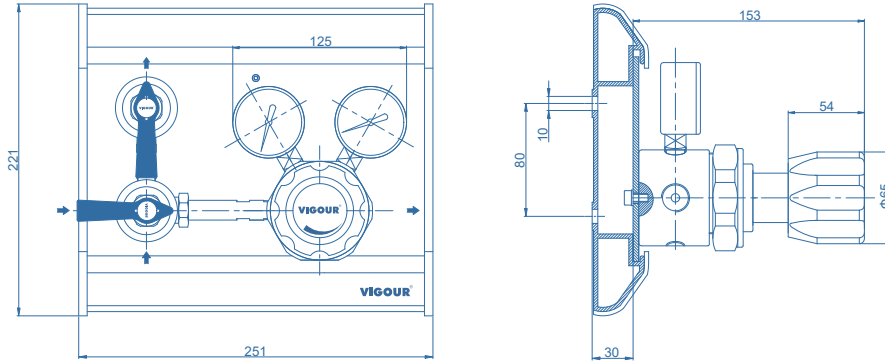

Ordering Information

VSP - 1HS - 300 - 10 - P - P - V - N₂

